

Industrijski ROBOTI



Prof. dr Dragan Milutinović
Prof. dr Zoran Miljković

14-Dec-07

Industrijski ROBOT

Def. (ISO 8373)

je višenamenska, reprogramabilna, manipulaciona i automatski upravljana mašina sa više stepeni slobode, koja može biti u fiksiranom položaju ili mobilna, a koristi se za automatizovane industrijske primene.

14-Dec-07

Funkcionalna struktura IR

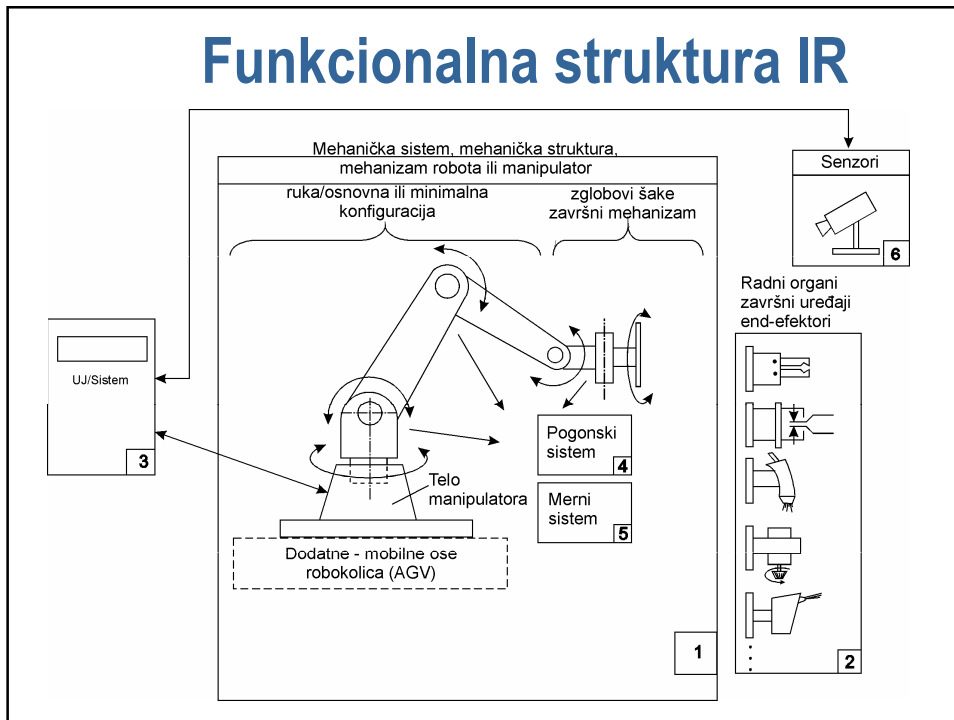

Roboti

- Sa serijskom kinematikom



- Sa paralelnom kinematikom

14-Dec-07

Osnovne tipske konfiguracije

- Dekartova
- Polarno cilindrična
- Sferna
- Horizontalna zglobna-laktasta SCARA
- Vertikalna zglobna-laktasta, antropomorfna (čovekolika)

14-Dec-07

Dekartova (TTT)

Cartesian Robot

14-Dec-07

Dekartova

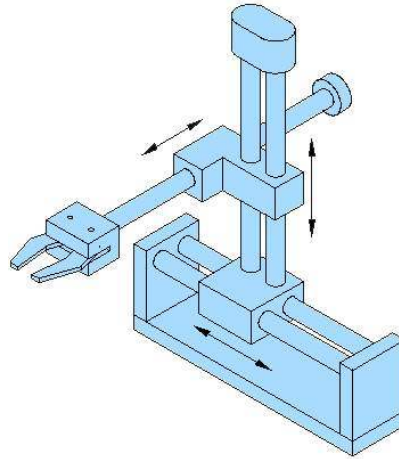

14-Dec-07

Dekartova

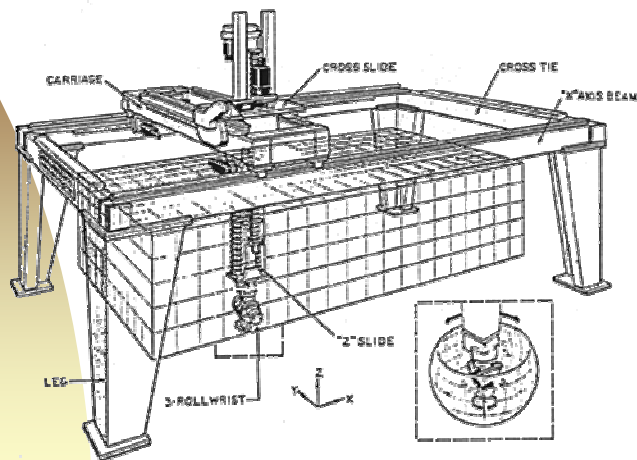

14-Dec-07

Cartesian & Gantry

Polarno-cilindrična (RTT)

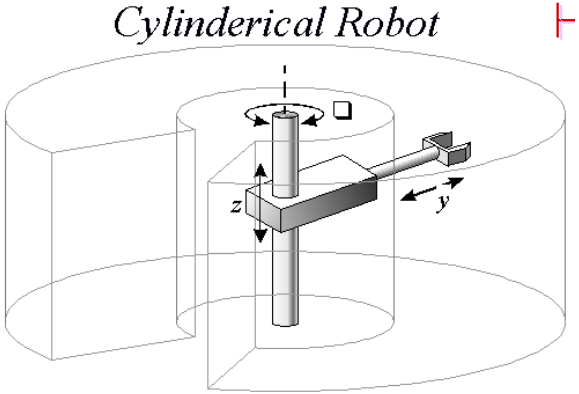

14-Dec-07

Polarno-cilindrična

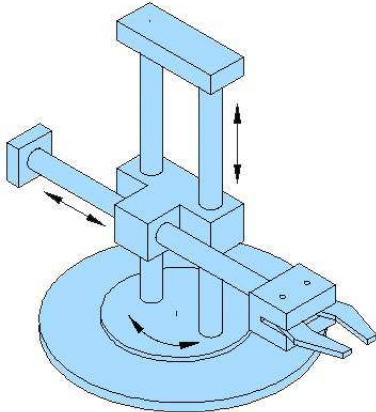

14-Dec-07

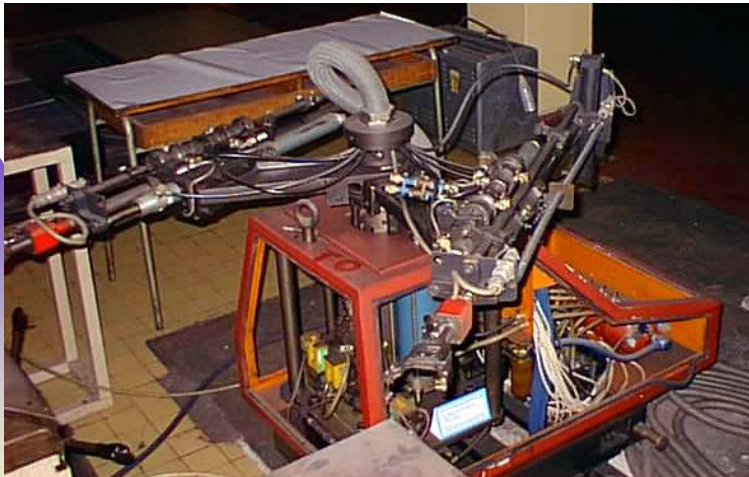

**Dvoruki
LOLA robot
RPD 1.25**
14-Dec-07



**Robotizovana
ćelija za
opsluživanje
ekscentar
prese - ZMA**
14-Dec-07

Sferna konfiguracija (RRT)

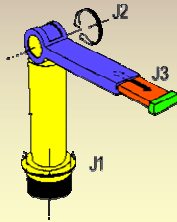

14-Dec-07

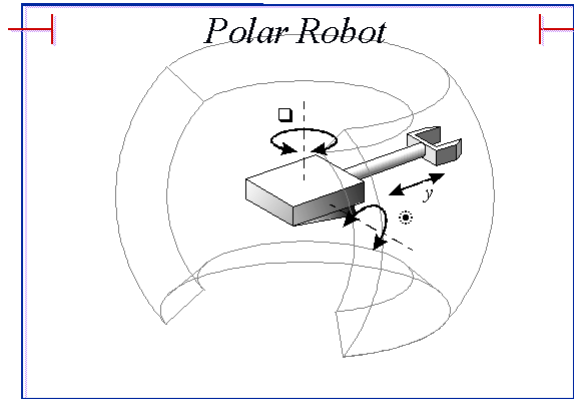

Horizontalna zglobna - SCARA (RRT ili TRR)

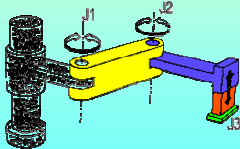

Selective Compliance Assembly Robot Arm

14-Dec-07

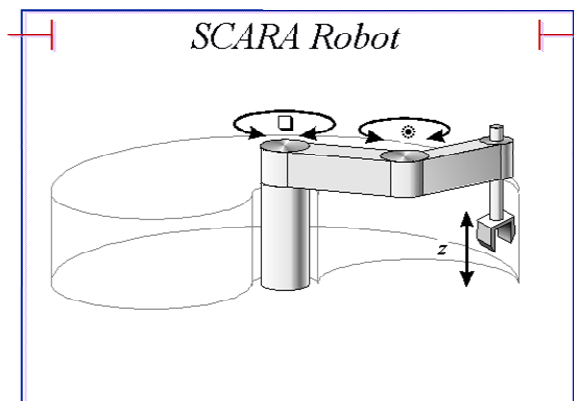

SCARA

palletized parts

parts conveyor

product conveyor

partially assembled products

assembly site

six-position turret on last link

wide conveyor

product

palletized kit

turning device

gate device

conveyor

product

parts feeder

turning device

Selective Compliance Assembly Robot Arm

14-Dec-07

Vertikalna zglobna (RRR)

J1

J2

J3



J1

J2

J3

14-Dec-07

Kawasaki Robot

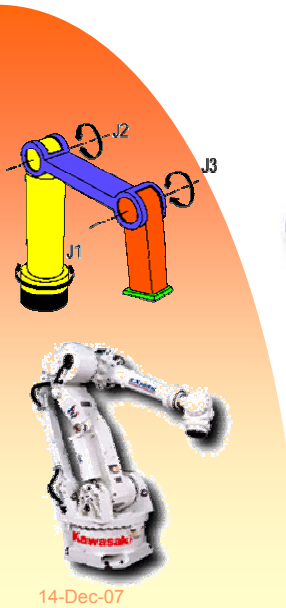

14-Dec-07

KUKA robot

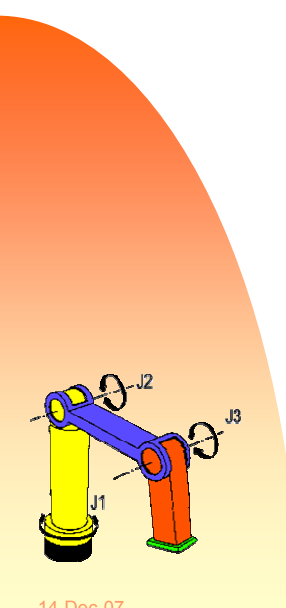

14-Dec-07

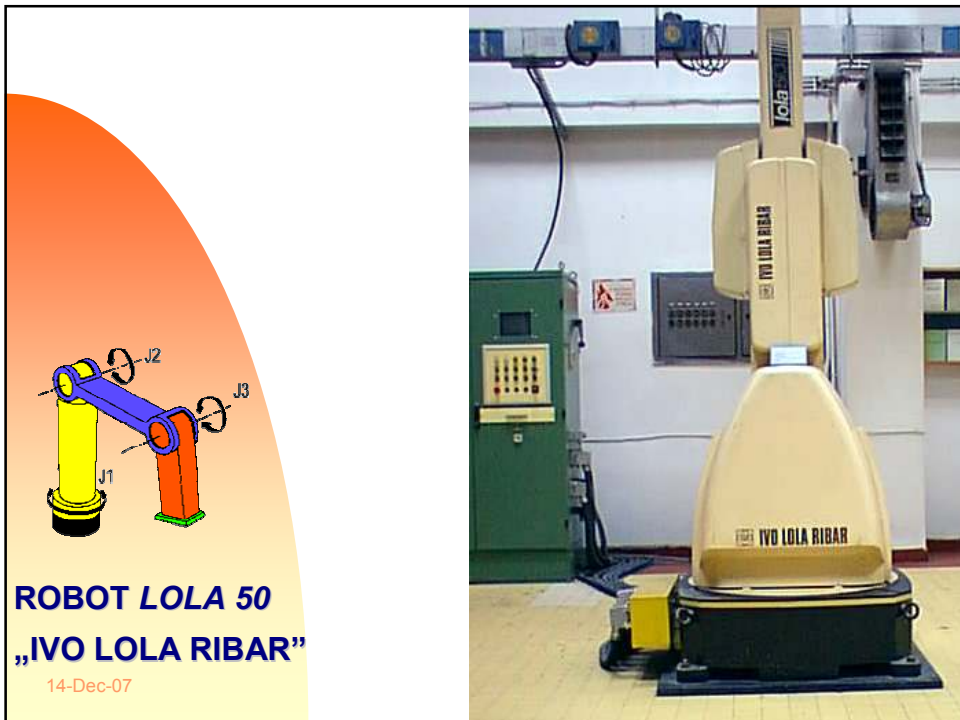

MovemasterEX



14-Dec-07

MovemasterEX

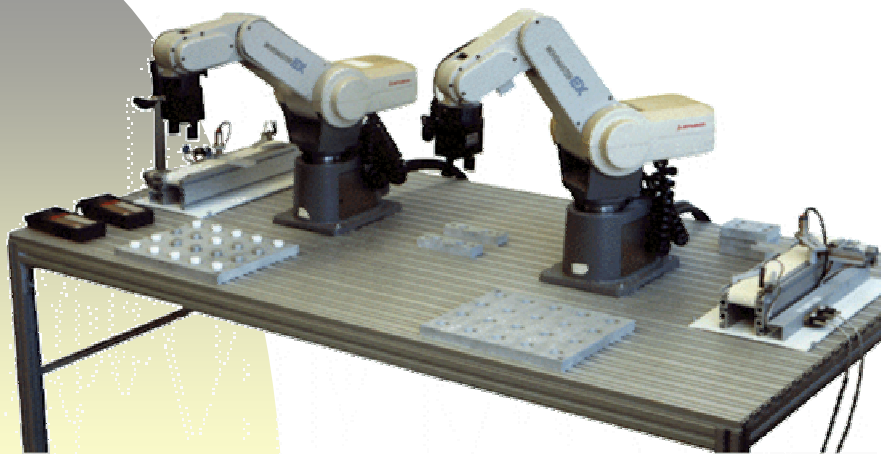

14-Dec-07

Tipovi kretanja IR

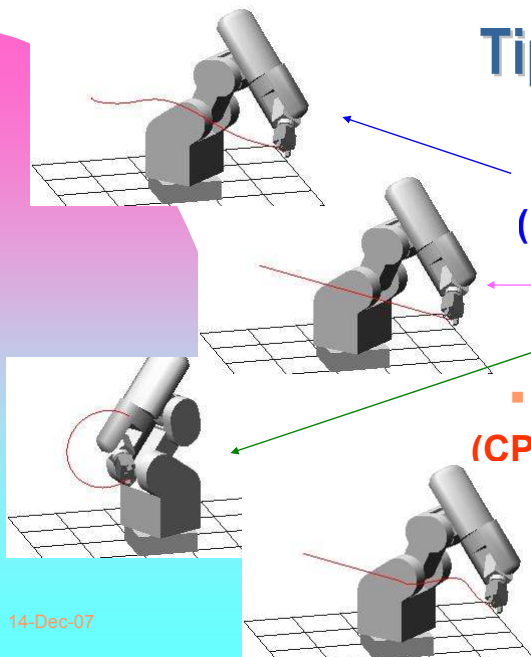

- Tačka po tačka (PTP - „Point to Point”)
- Linearna kretanja
- Kružna kretanja
- Kontinualna kretanja (CP - „Continuous Path”)

14-Dec-07

Primeri instalisanja

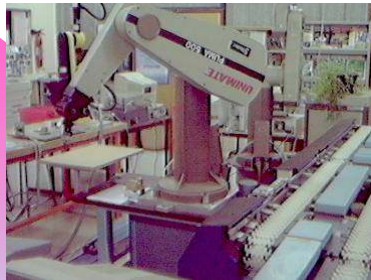

- Podni



- Laboratorijski (na stolu)

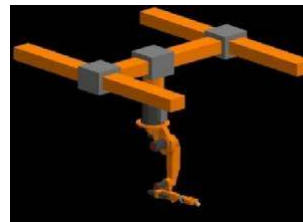

- Viseći - „njihajući”

14-Dec-07



• AGV - robokolica



• Šinski



• Viseći - šinski

14-Dec-07

Klasifikacija IR (sa stanovišta funkcije i primene)

MANIPULACIJA

OBAVLJANJE
PROCESA

MANIPULACIJA
I OBAVLJANJE PROCESA

SPECIJALNI
ZADACI

14-Dec-07

MANIPULACIJA

Premeštanje objekata sa jedne na drugu lokaciju

- Paletizacija / Depaletizacija
- Opsluživanje regalnih skladišta
- Opsluživanje mašina (manipulacija pripremcima i gotovim delovima u zoni obrade)
- Pakovanje
- ...

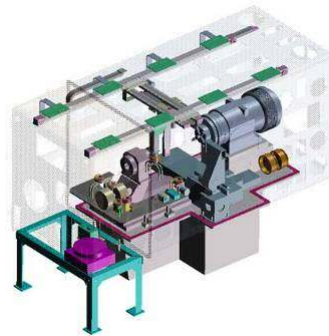
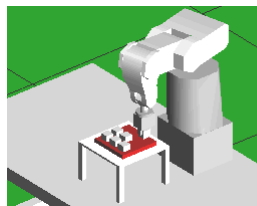

14-Dec-07

OBAVLJANJE PROCESA

- Zavarivanje
 - ◆ tačkasto, elektrolučno ...
- Obrada REZANJEM
 - ◆ brušenje, obaranje ivica, poliranje, bušenje, odsecanje nalivaka ...
- Sečenje
 - ◆ laserom, plazmom, vodenim mlazom
- ...



14-Dec-07

MANIPULACIJA I OBAVLJANJE PROCESA

Upotreba IR u funkciji
manipulacije delom i
obavljanja procesa u
MONTAŽI:

- automobila,
- motora,
- čipova,
- ...



14-Dec-07

SPECIJALNI ZADACI

- **Merenje i kontrola kvaliteta**
- **Kontrola u nuklearkama**
- **Istraživanje kosmosa**
- **Uklanjanje mina**
- ...

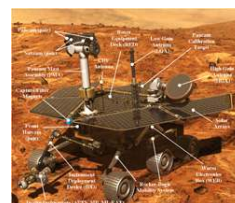

14-Dec-07

End - efektori (EE)

EE ili završni mehanizam treba da bude univerzalan, lako izmenljiv i spojiv pomoću „interface” ploče sa segmentom IR.

EE mogu biti:

- Hvatači
- Alati
- Merni pipci
- ...

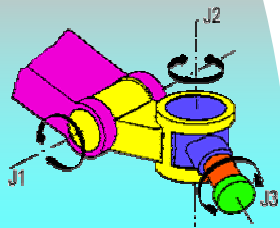

14-Dec-07

End-efektor - Hvatač

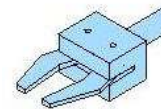

14-Dec-07

End-efektor - ALAT

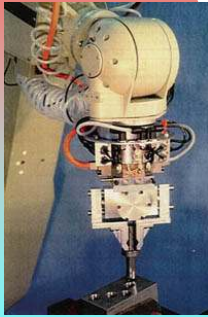

14-Dec-07

Primeri primene IR



Industrial robots



14-Dec-07

Primeri primene IR

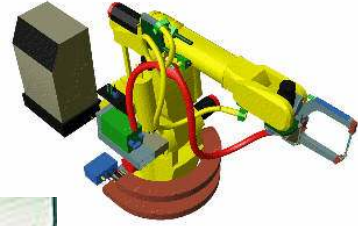

Primeri primene IR

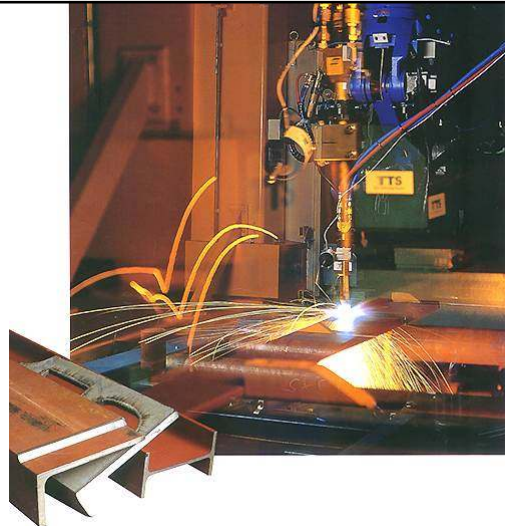

Primeri primene IR



14-Dec-07

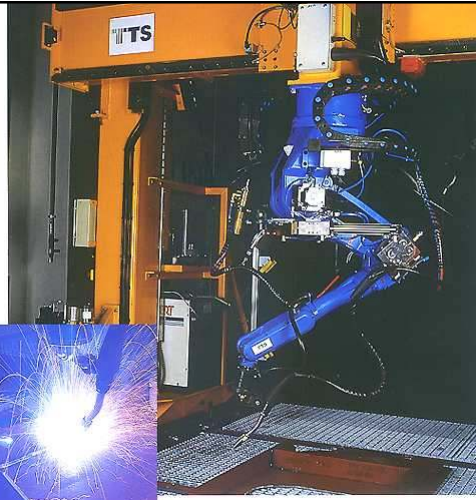

Primeri primene IR



14-Dec-07