

# Обрадни системи

## Струг

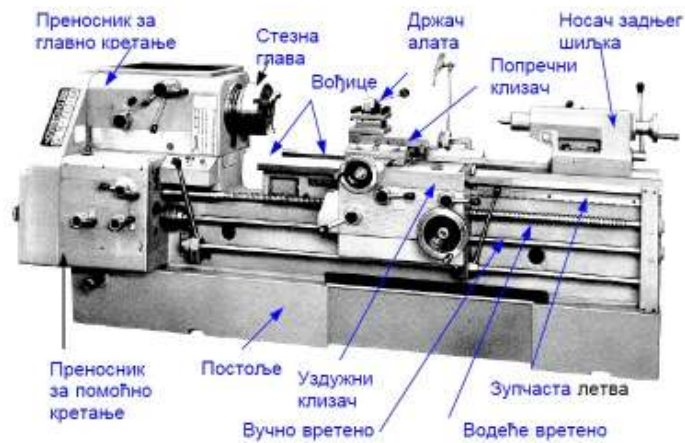

## Револютер струг

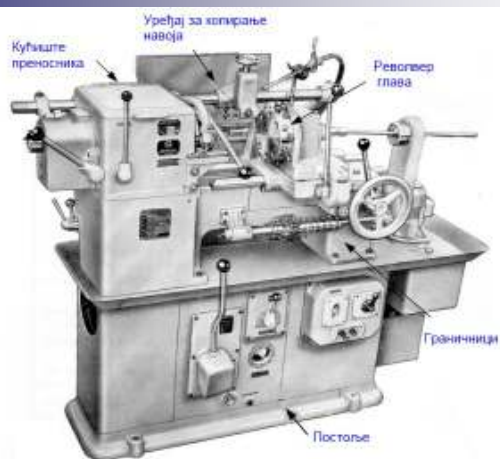

41

## Вертикални струг



42

## НУ Струг



## Дугохода рендисаљка

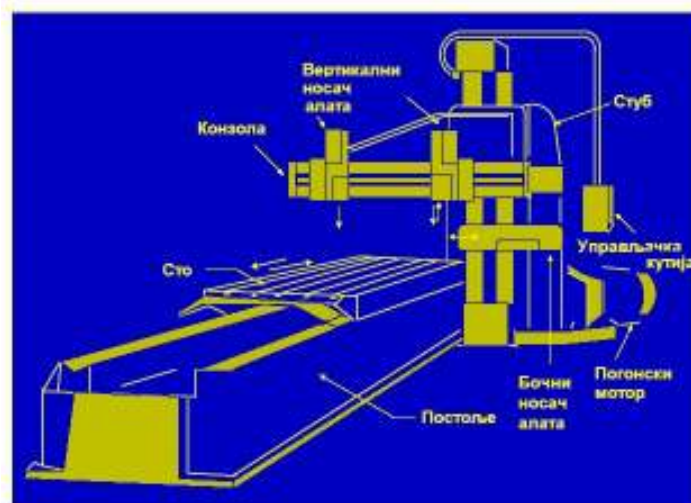

## Краткохода рендисаљка

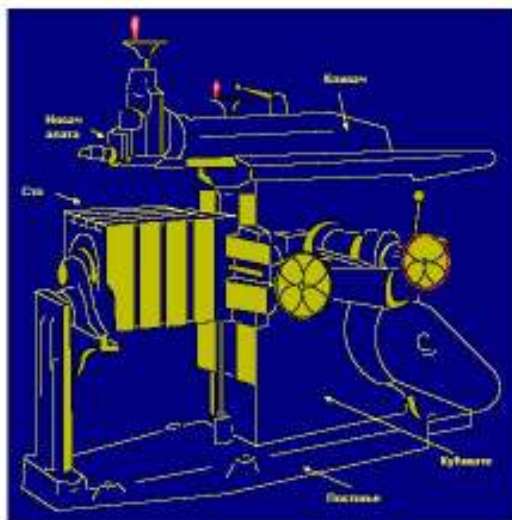

45

## Вертикална рендисаљка



46

## Стубна бушилица

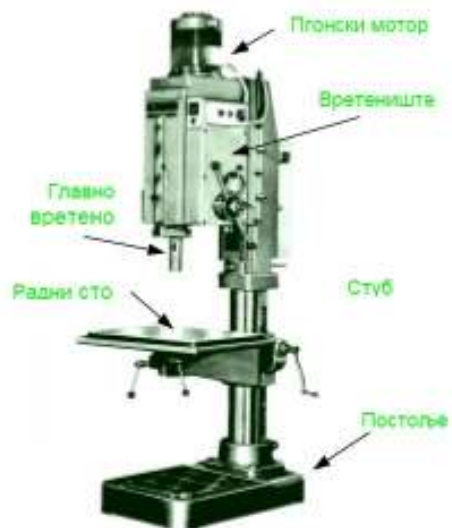

47

## Радијална бушилица



48

## Вишевретена бушилица

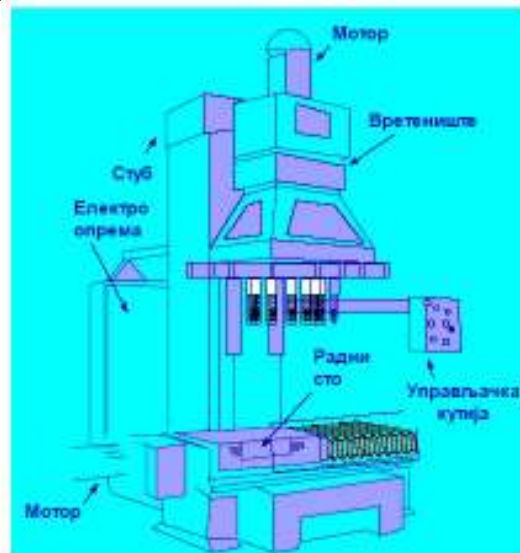

49

## Хоризонтална глодалица

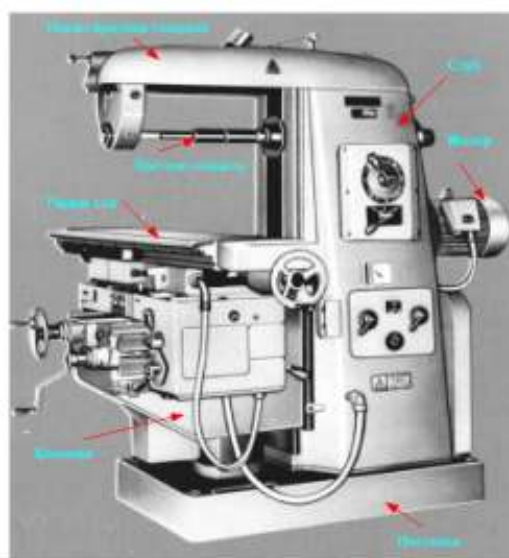

50

## Вертикална глодалица

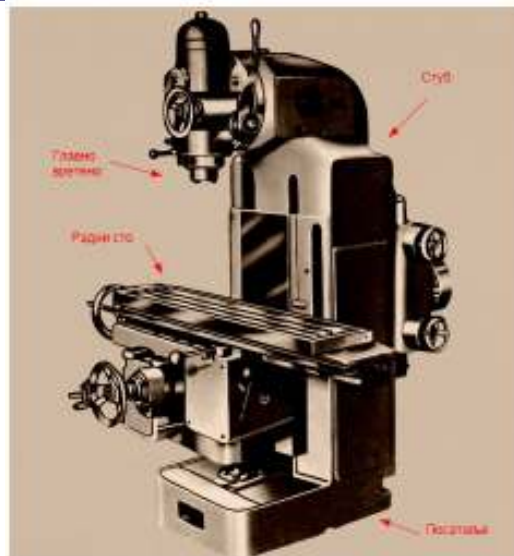

51

## Тестера

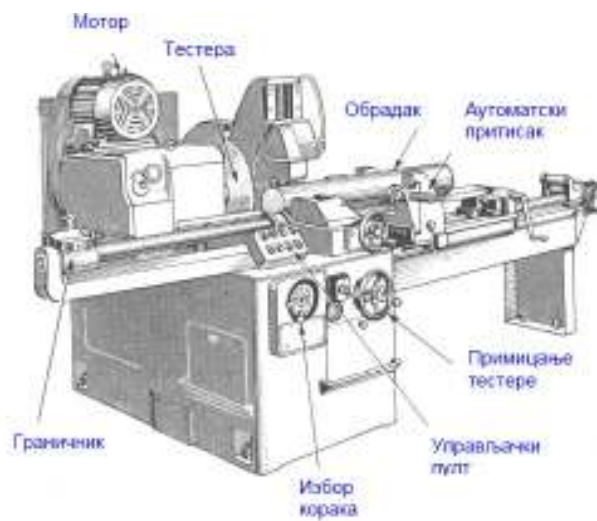

52

## Брусилаца за округло брушење

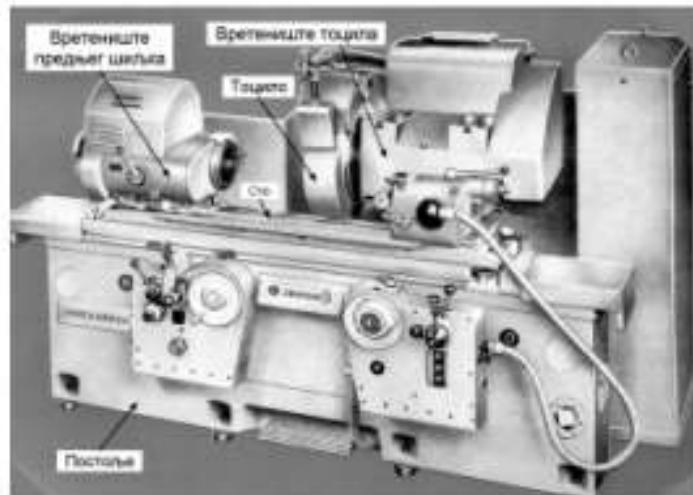

53

## Брусилаца за равно брушење



54



## Хоновање

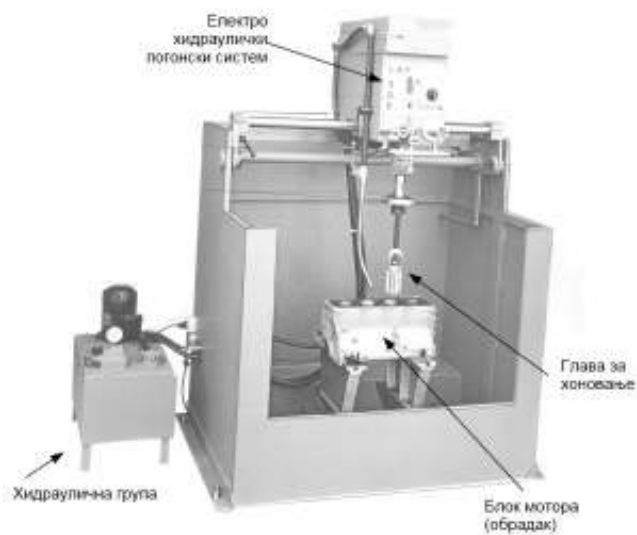

55

## Машина за леповање



56

## Обрадни центар

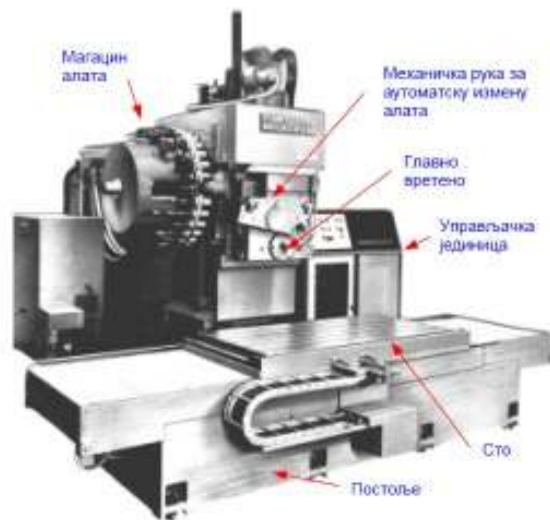

## Обрадни центар

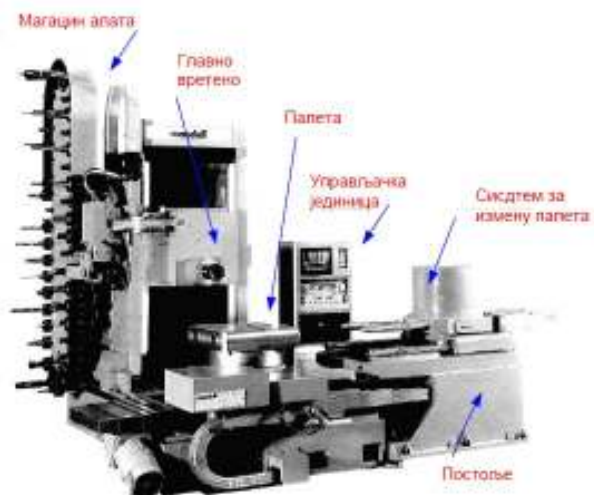

## Стругарски нож

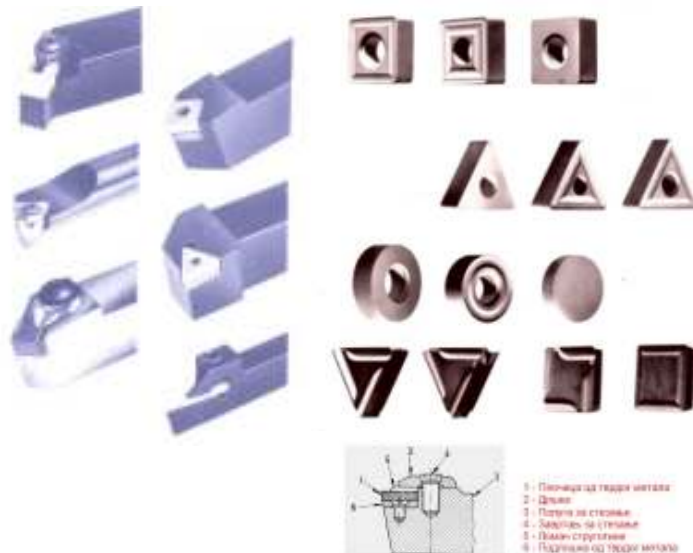

59

## Алати за обраду отвора

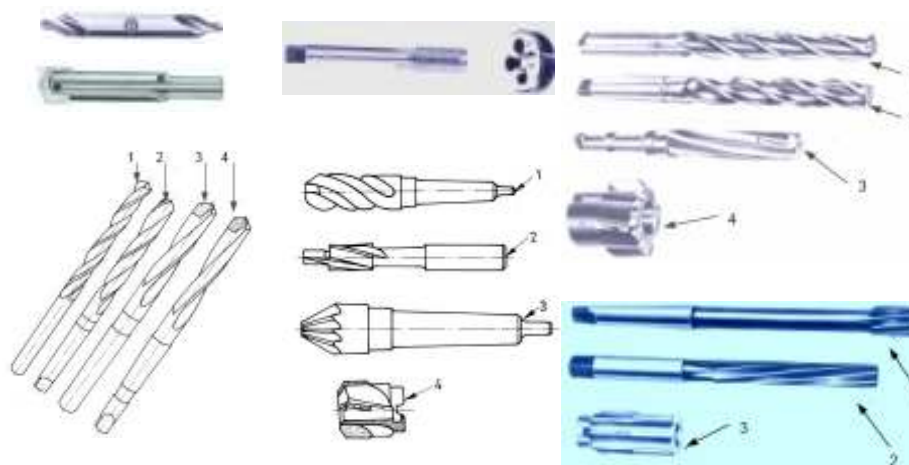

60



## Стезни прибори



63

## Слободно падни чекић



64

## Парни чекић

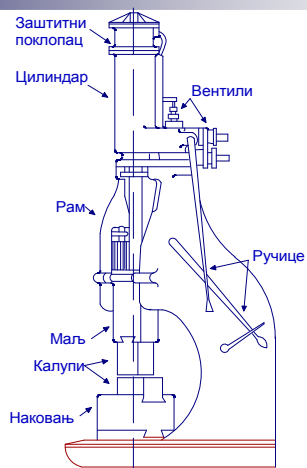

65

## Ваздушни хоризонтални чекић двоструког дејства

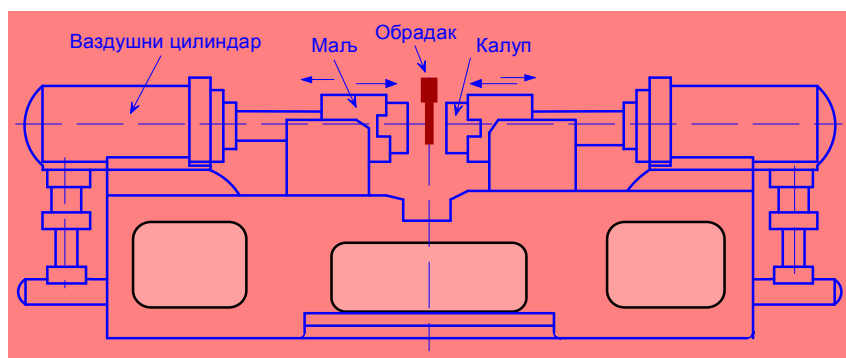

66

## Чекић двоструког дејства са челичним тракама

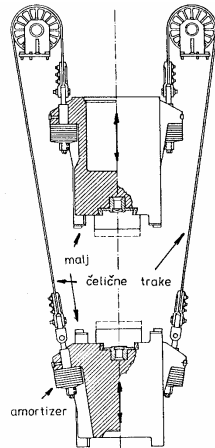

67

## Фрикциона пресе са два диска

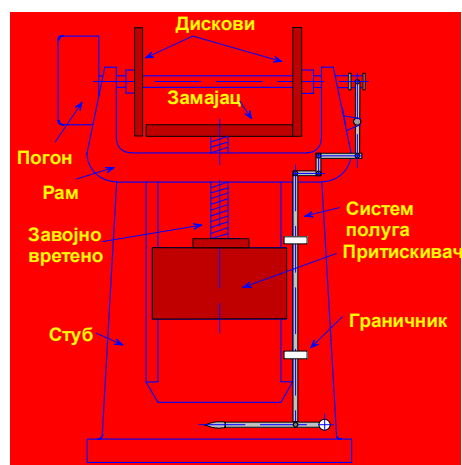

68

## Ексцентар преса



69

## Машина за савијање

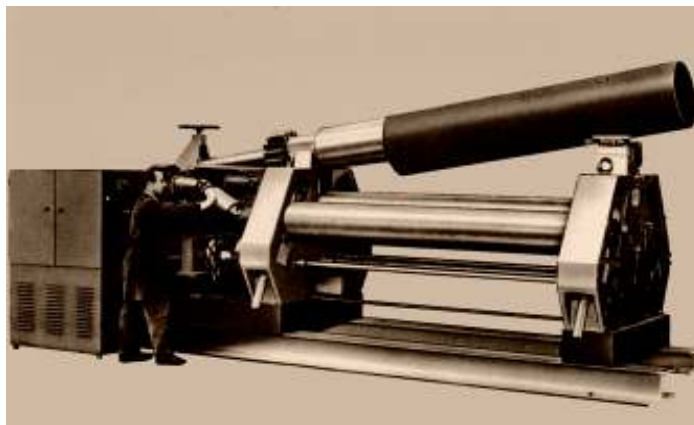

70



## Машина за савијање



71

## Машина за пробијање

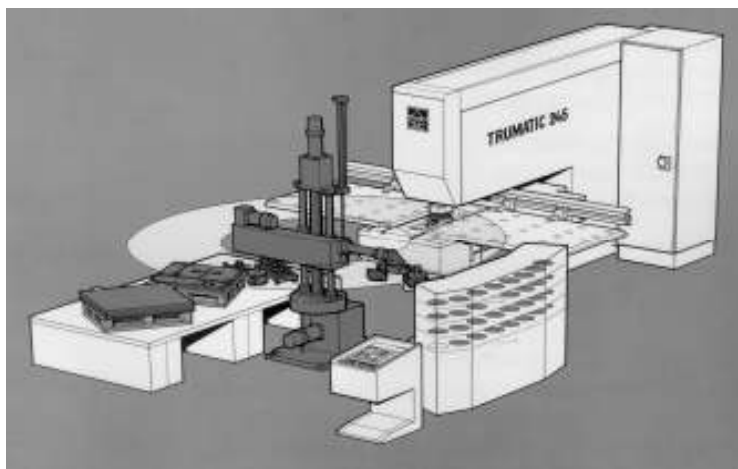

72

## Алати за ковање – отворен калуп

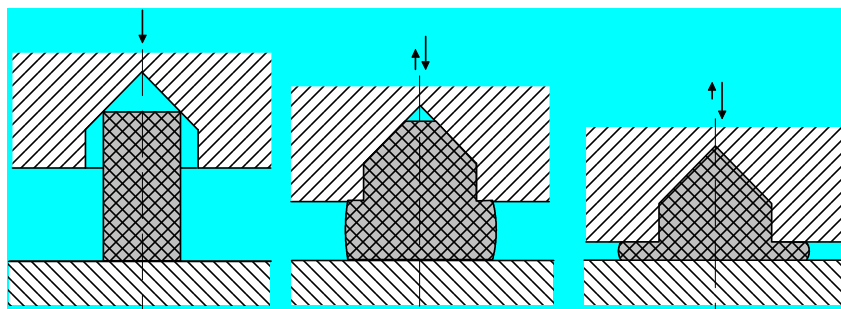

73

## Алати за ковање – затворен калуп

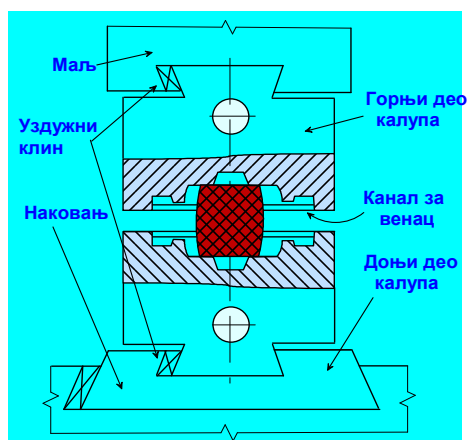

74

## Алати за обраду лима – алат за извлачење

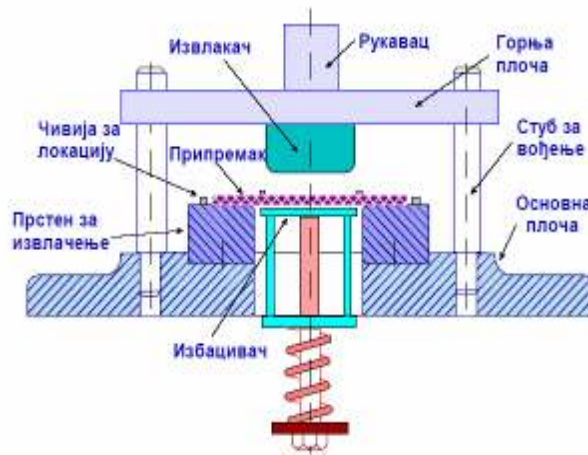

75

## Алати за обраду лима – паралелни алат за пробијање и просецање

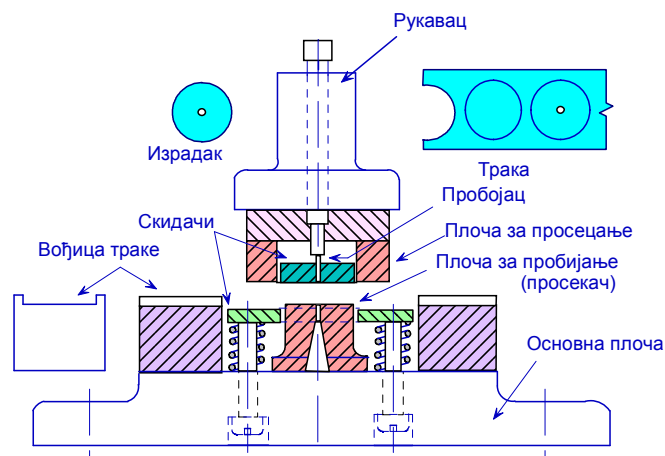

76